

# +GF+ SIGNET 525 Metalex Flow Sensor



## Features

- 316SS body
- High pressure and temperature capability
- FM & CSA approved
- DN15 to DN50 (0.5 to 12 in.) pipe range
- Simple Installation
- Tungsten Carbide shaft
- CE

## Application

- Boiler Feedwater Monitoring
- HVAC Systems
- Chemical Transport
- Heat Exchangers
- Reverse Osmosis

## Description

The +GF+ SIGNET 525 Metalex Flow Sensor combines stainless steel construction with insertion paddlewheel technology. The result is a highly reliable sensor suitable for operation at extreme pressures and temperatures. The Tungsten Carbide shaft with Fluoroloy B<sup>®</sup> bearing provides an extended maintenance interval.

A comprehensive fitting program allows installation in steel lines with the mini-block for small diameters, and either the mini-tap or saddle for pipes up to DN300 (12 in.). The self-generating output signal allows use with battery operated flow monitor (3-5100).

## Options

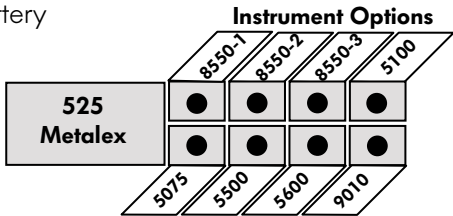

## Technical Features

- 1/2 in. NPT Conduit Connection
- Cast and machined stainless steel body
- Tungsten carbide shaft with Fluoroloy B<sup>®</sup> bearing for extended service
- CD4MCu stainless steel rotor
- Open-cell rotor

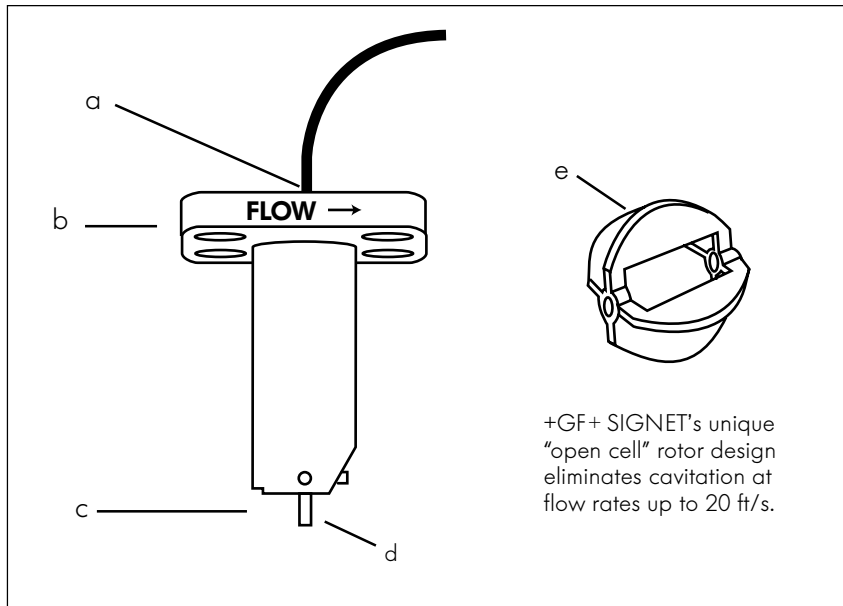

+GF+ SIGNET's unique "open cell" rotor design eliminates cavitation at flow rates up to 20 ft/s.

## Dimensions

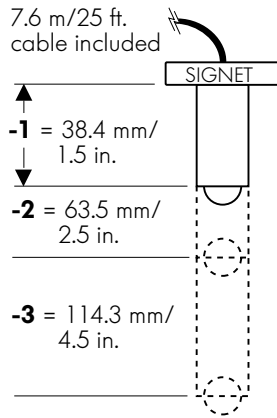

## Fitting Types

(Refer to Fittings Section for ordering information)

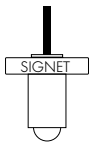

P525-1  
Sensor

Wetted fitting materials:  
316 SS

- Socket weld
- 0.5 in. to 1.0 in.
- cap included

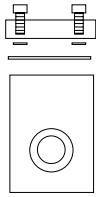

Socket weld Mini-Tap fitting,  
hardware included

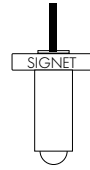

P525-2  
Sensor

Wetted fitting materials:  
316 SS & 347 SS

- 1.25 in. to 12 in.
- cap included

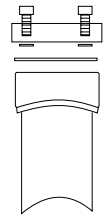

Weld-On Mini-Tap Fitting,  
hardware included

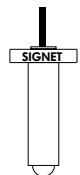

P525-3  
Sensor

Wetted fitting materials:  
Ductile Iron, 347 SS,  
Carbon steel,  
Buna-N/Neoprene

- 2 in. to 12 in.
- cap included

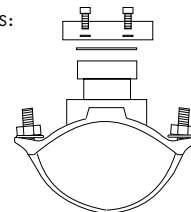

Saddle Fitting,  
hardware included

## Wiring

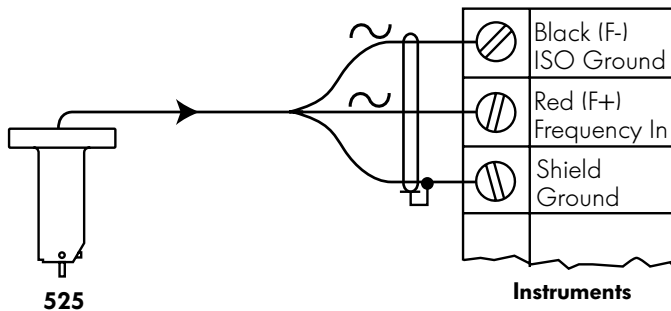

## Installation

Six common installation configurations are shown here as guidelines to help you select the best location in your system for a paddlewheel flow sensor. Always maximize distance between sensor and pump sources.

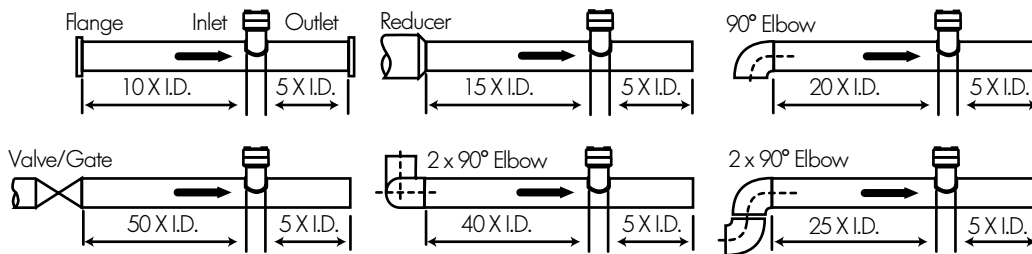

## Sensor Mounting Position

- Horizontal pipe runs: Mount sensor in a vertical position for best performance, or at a maximum 45° angle to avoid air bubbles (pipe must be full). Do not mount the sensor on the bottom of the pipe if sedimentation is likely.
- Vertical pipe runs: Mount sensor in any orientation. Upward flow is preferred to ensure full pipe

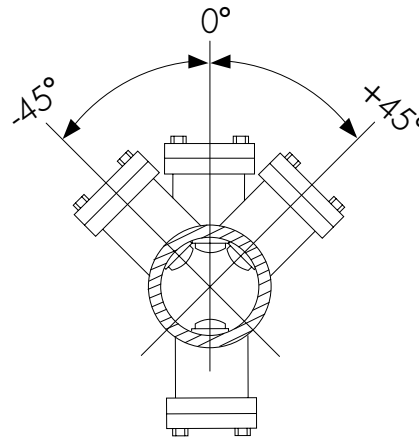

## Technical Data

### General

Flow Rate Range:	0.5 to 6 m/s (1.6 to 20 ft/s)	
Linearity:	± 1% of full range	
Repeatability:	± 0.5% of full range	
Minimum Reynolds # required:	4500	
Pipe size range:	DN15 to DN300 (0.5 to 12 in.)	
Cable length:	7.6 m (25 ft), can splice to 60m (200 ft) with no significant degradation of signal strength	
Cable type:	22 AWG, 2-conductor w/shield, 150°C max.	
Shipping Weight:		
P525-1	723 grams	1.6 lbs.
P525-2	774 grams	1.7 lbs.
P525-3	923 grams	2.0 lbs.

### Wetted Materials

Sensor body:	316SS (ACI type CF-8M per ASTM A351), DIN 17440
Rotor material:	SS (CD4MCu Alloy)
Rotor pin:	Tungsten Carbide GRP 1
Retainers (2):	316 stainless steel
Rotor bearings (2):	Fluoroloy B®
Gasket:	KLINGER®sil C-4401

### Electrical

Frequency:	12 Hz per ft/s nominal, 5 to 8 mV p-p per Hz
Source Impedance:	11.6 KΩ

### Maximum Pressure/Temperature

Socket Weld or Weld-On Mini-Tap fittings:	103 bar (1500) psi @ 149°C (300°F)
Saddle fitting:	21 bar (300) psi @ 66°C (150°F) for

### Standards and Approvals

- Manufactured under ISO 9001 and ISO 14001
- CE
- FM Class I, II, III, Division 1/Groups A-G
- CSA

KLINGER®sil is a registered trademark of Thermoseal, Inc.

## Ordering Information

Mfr. Part No.	Code	Description
P525-1	198 801 494	Sensor for Tee, 0.5 to 1 in.
P525-2	198 801 495	Sensor for Mini-Tap, 1.25 to 12 in.
P525-3	198 801 496	Sensor for Saddle, 2 to 12 in.

+GF+ SIGNET Metalex Socket Weld Mini-Tap, Weld-On Mini-Tap and Saddle fittings purchased separately, see Fittings section.

## Accessories

Mfr. Part No.	Code	Description
P51589	159 000 476	Conduit Adapter Kit
P52618	159 000 493	Gasket
P52628	159 000 504	Fitting cap kit (cap and gasket)
P52509	198 801 501	Rotor kit (rotors, stainless steel pin, bearings, retainers)
P52509-2	159 000 480	Rotor kit (rotors, tungsten carbide pin, bearings, retainers)
P52504-1	198 801 500	Rotor Shaft, Stainless steel (optional)
P52504-2	198 820 023	Rotor Shaft, Tungsten Carbide (standard)
P52503	198 820 013	Bearing, Fluoroloy B®
P52527	159 000 481	Retainers, Stainless steel
5523-3222	159 000 393	Cable (per foot) 2 cond. w/shield, 22 AWG

## Engineering Specifications

- The flow sensor shall use a four-blade, open-cell rotor design using insertion paddlewheel technology.
- The sensor shall be available in models usable in pipe sizes from DN15 to DN50 (0.5 to 12 in.) when combined with appropriate installation fittings.
- The sensor shall require no electrical power.
- The sensor shall provide an output signal of 80 mV p-p per ft/s nominal at a frequency of 12 Hz per ft/s nominal from 1.6 to 20.0 ft/s.
- Output shall be via a twisted pair, foil-shielded cable with drain wire. Supplied cable shall be at least 7.6m (25 ft) long, with a maximum allowable length of 61 m (200 ft).
- Linearity of the output signal with respect to flow rate shall be  $\pm 1\%$  of full scale.
- Measurement repeatability shall be  $\pm 0.5\%$  of full scale.
- The operating range of the sensor shall accommodate nominal flow rates from 0.5 to 6 m/s (1.6 to 20 ft/s).
- The sensor body shall be made of ACI type CF-8M (316 SS) per ASTM A 351 that shall accommodate up to 103 bar (1500) psi @ 149°C (300°F) with appropriate installation fitting.
- Shaft shall be Tungsten Carbide. Retainers shall be made of 316SS. Rotor shall be made of CD4MCu alloy.
- The sensor shall attach to a pipe via a variety of insertion-style installation fittings supplied by the flow sensor manufacturer.
- The sensor shall be equipped with 0.5 in. NPT female threaded conduit connection.
- The sensor shall meet appropriate CE, FM standards for Classes I, II and III, Division 1/Groups A-G and CSA.
- The flow sensor shall be +GF+ SIGNET 525 Metalex.